

Short-term outdoor signage with HP Production Coroplast Board and HP PageWide XL Pro

This document explains how to use HP's new Production Coroplast Board to quickly create outdoor short-term signage using HP PageWideXL Pro printers.



Short-term outdoor signage with HP Production Coroplus Board



What you will need

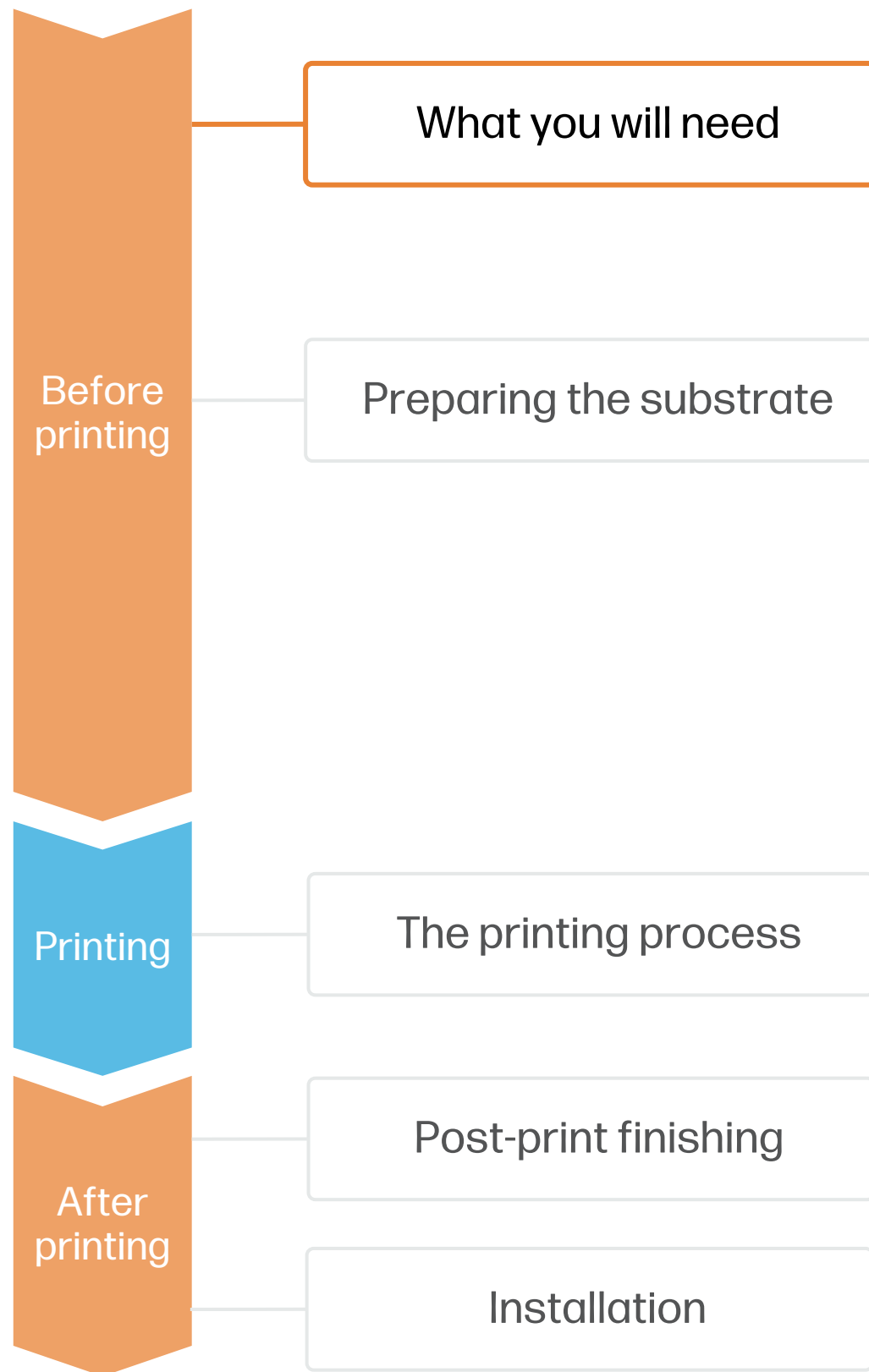

HP Production Coroplus Board

Software tools (RIP, edition, etc.)

HP PageWide XL Pro printer

H-frame stake (if installing on the ground)

Heavy duty cable ties & a grommet press (if installing on pole)

Utility knife & safety edge ruler (if cutting/bending)

40" wide rigid board for printhead alignment calibrations

A calibratable 40" roll for color uniformity calibrations

Preparing the substrate

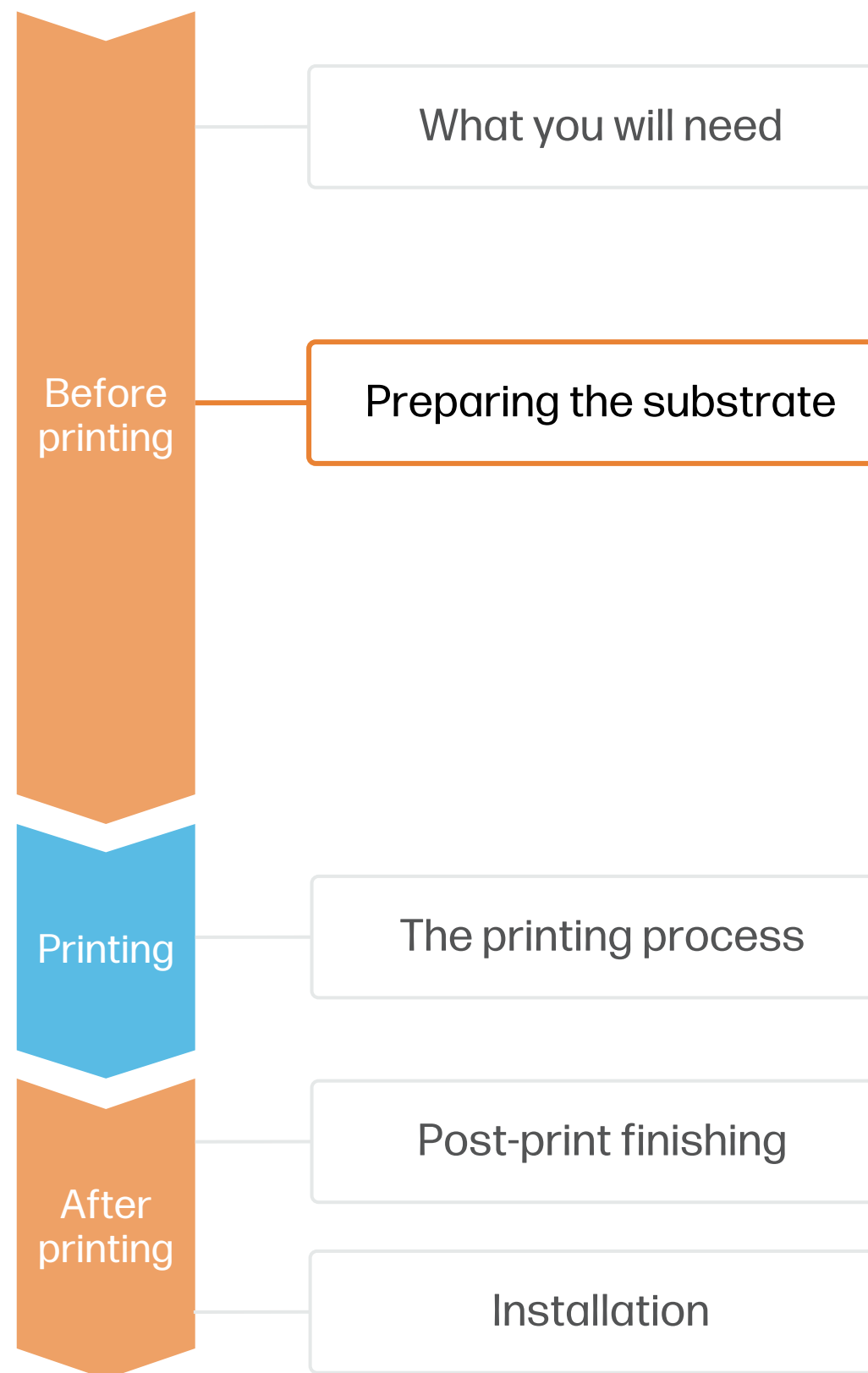

1. Substrates for short-term outdoor signage

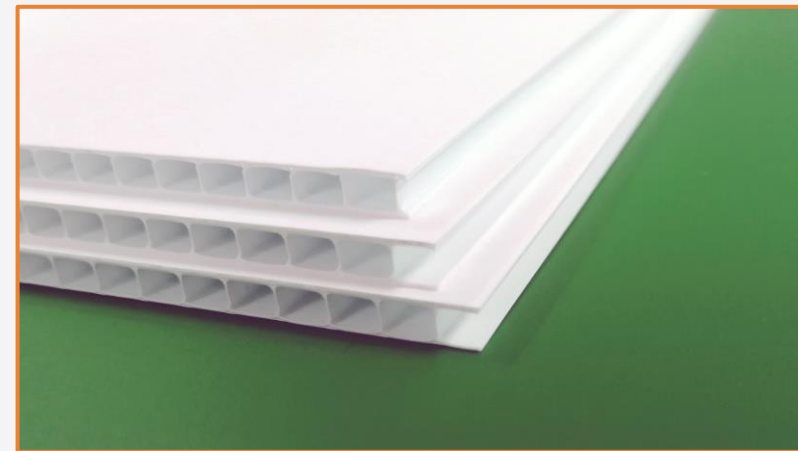

- [HP Production Coroplast Board](#) is the only **corrugated plastic board** that can be printed directly on HP PageWideXL Pro. It is a fluted polypropylene board with an ink receptive coating specifically designed for PageWideXL inks, drying instantly after printing and producing highly saturated colors.
- **Thickness:** 0.157" (4mm)
- **Sizes & Product availability:**
 - 7N3Y3A – 18 in x 12 in (457 mm x 304 mm), 25-sheet Pack
 - 7N3Y4A – 24 in x 18 in (610 mm x 457 mm), 25-sheet Pack
 - 7N3Y5A – 36 in x 24 in (914 mm x 610 mm), 20-sheet Pack
- HP Production Coroplast Board **can be printed on both sides** of the board.

⚠ IMPORTANT: Corrugated plastic boards sold for Latex or UV printers **do not work** with HP PageWideXL Pro unless they have a receptive coating for aqueous inks.

2. Usage

- HP Production Coroplast Board is best suited for **short-term outdoor signage** applications (typically < 2 months).

⚠ IMPORTANT: It is strongly recommended not to handle the printed boards if they get wet, since the ink can be rubbed off. Wait until they get dry again to safely install the boards. If wet handling is a key necessity, try printing on [HP Latex R printer series](#).

Preparing the substrate

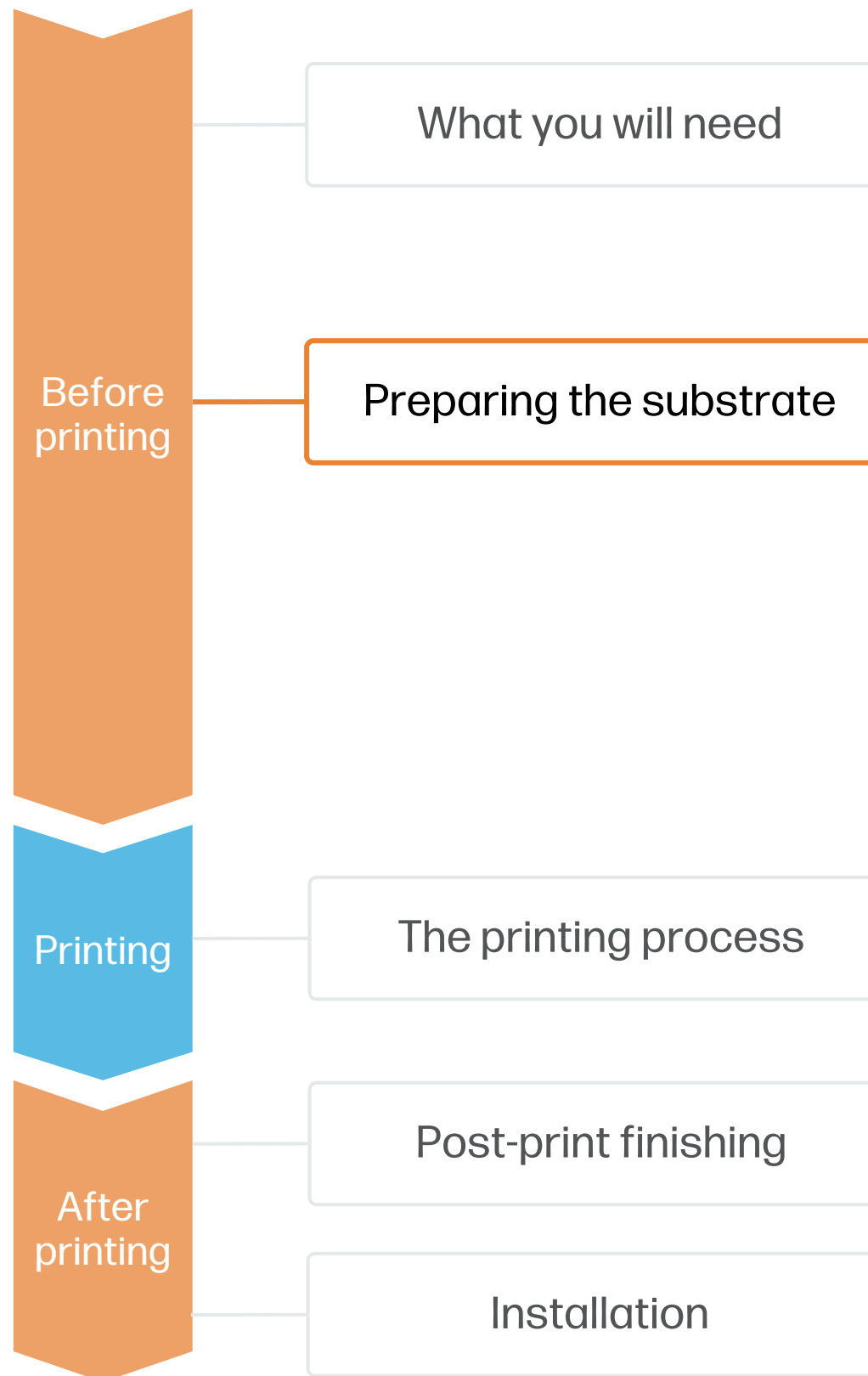

3. Storage

Store HP Production Coropius Board horizontally and in its original packaging whenever possible. Keep the boards in a clean, dust-free environment.

Shelf life: 2 years, unopened in original packaging

Storage temperature: 15 to 35° C / 59 to 95° F

Storage humidity: 15 to 30% RH

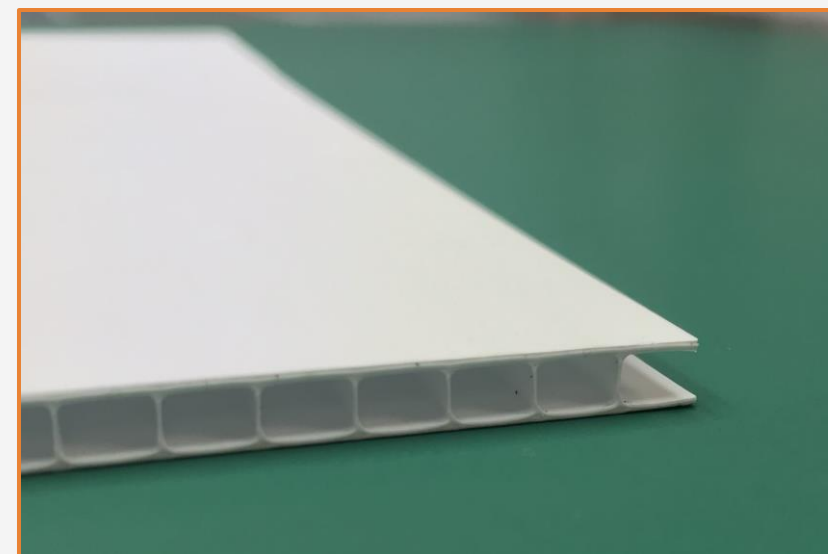

4. Handling

Be careful not to damage the board's edges, as this damage can cause crashes during printing.

Wear gloves when handling the boards to avoid getting fingerprints marks on the surface which may become visible after printing.

The printing process

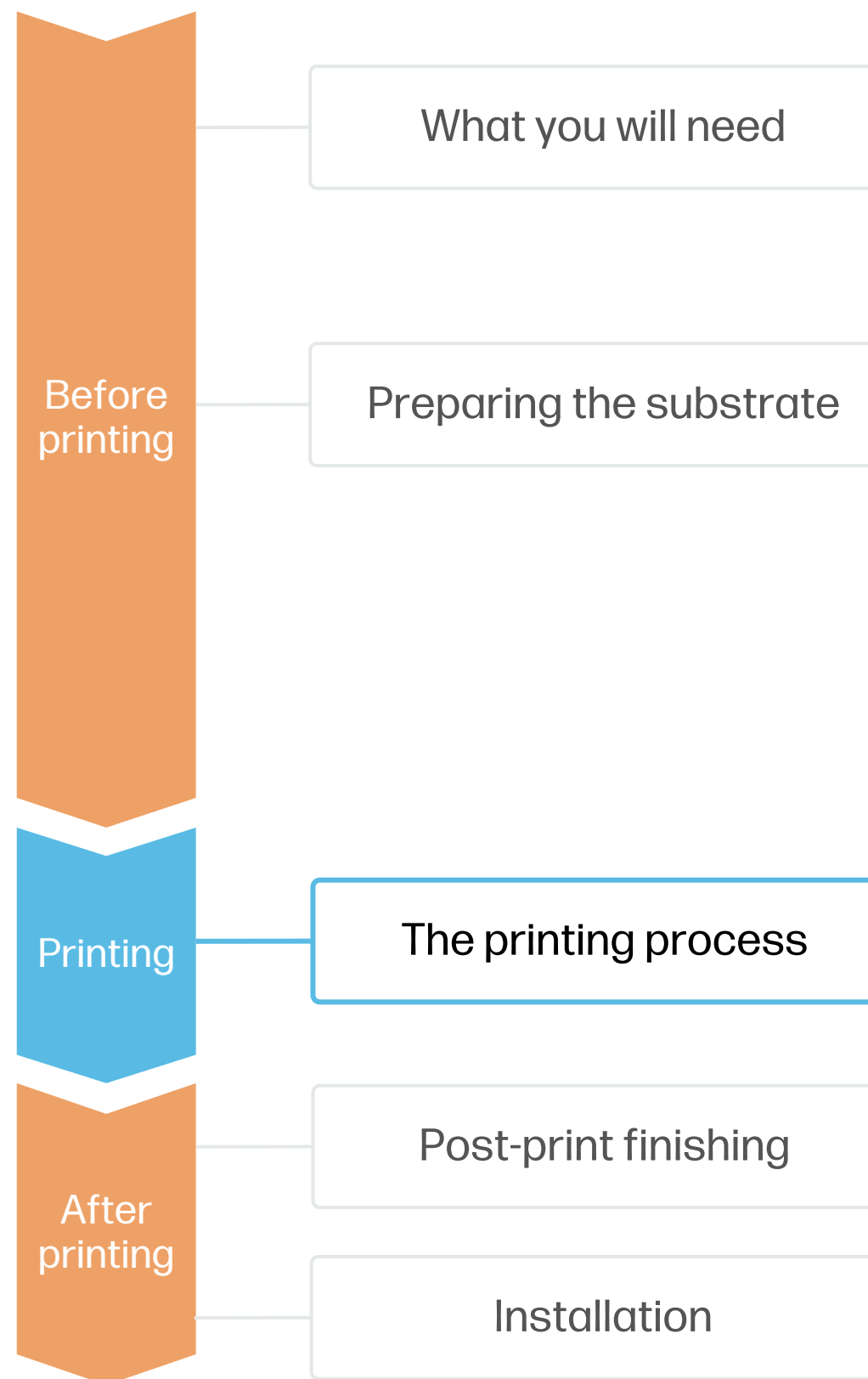

5. Loading the boards

1 | If it is your first time using HP Production Coroplus Board, perform PageWideXL's basic calibrations:

- **Automatic Printhead Alignment:** Use a 40" wide rigid board for this calibration, such as 3A Fome-Cor Sirius.
- **Color Uniformity Calibration:** Use a calibratable 40" roll for this calibration, such as HP Universal Heavyweight Coated Paper 40"

Follow this [Calibration guide](#) if you need more help.

2 | Use the online search function within the Paper library front-panel menu to **install HP Production Coroplus Board's optimized printing preset.**

3 | **Load the first board** through the input tray by clicking on Paper app and selecting sheet load.

- Load **18"x12"** & **24"x18"** sizes in **portrait** (short edge first) orientation.
- Load **36"x 24"** size in **landscape** (long edge first) orientation.

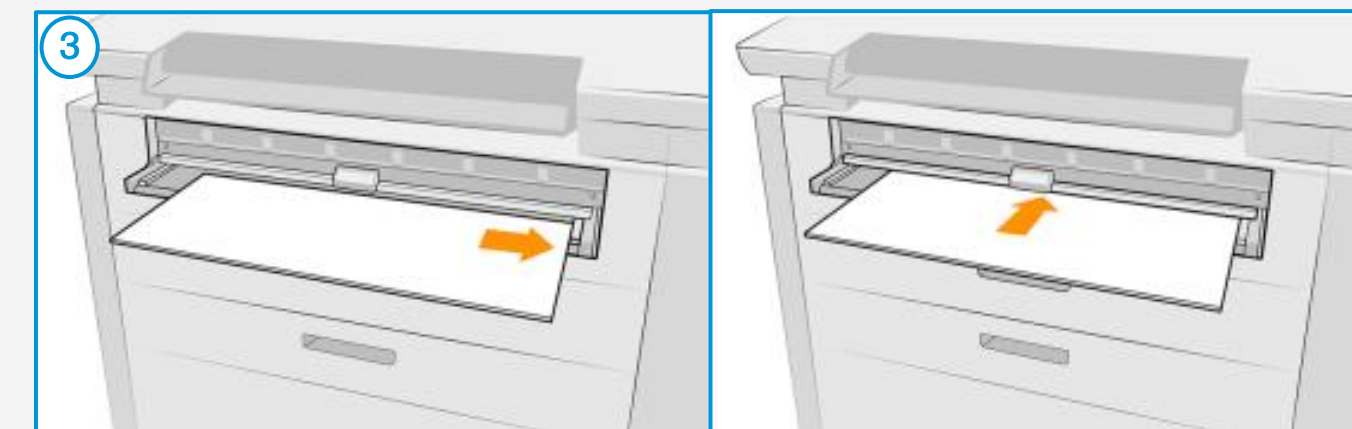
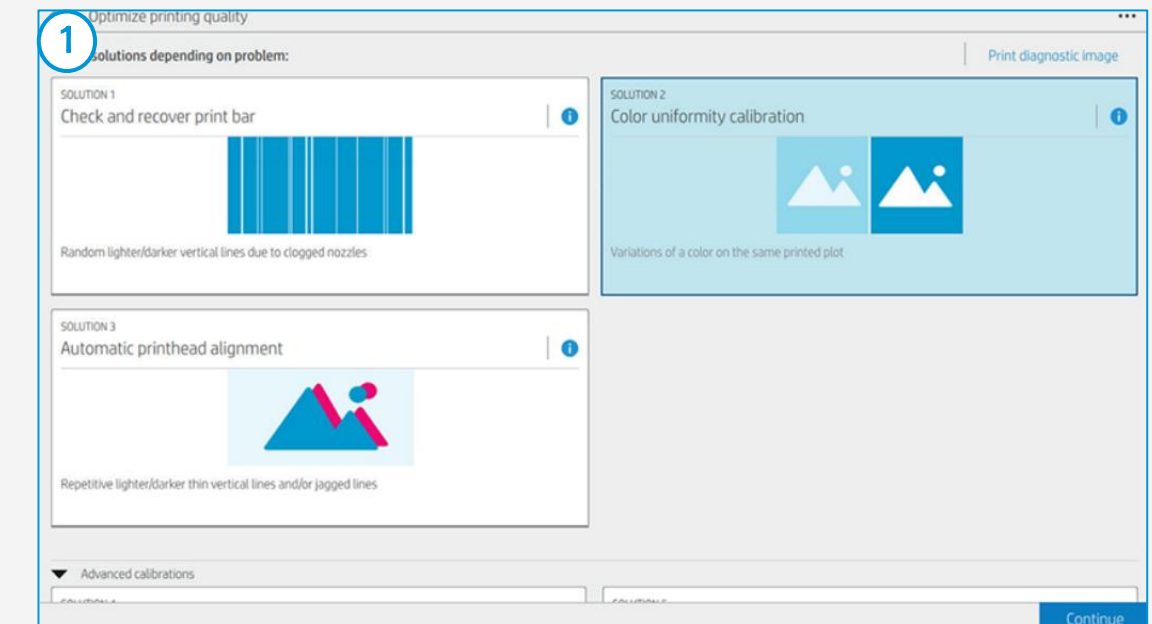

TIP: Check this [short video guide](#) if you need help with the loading process.

The printing process

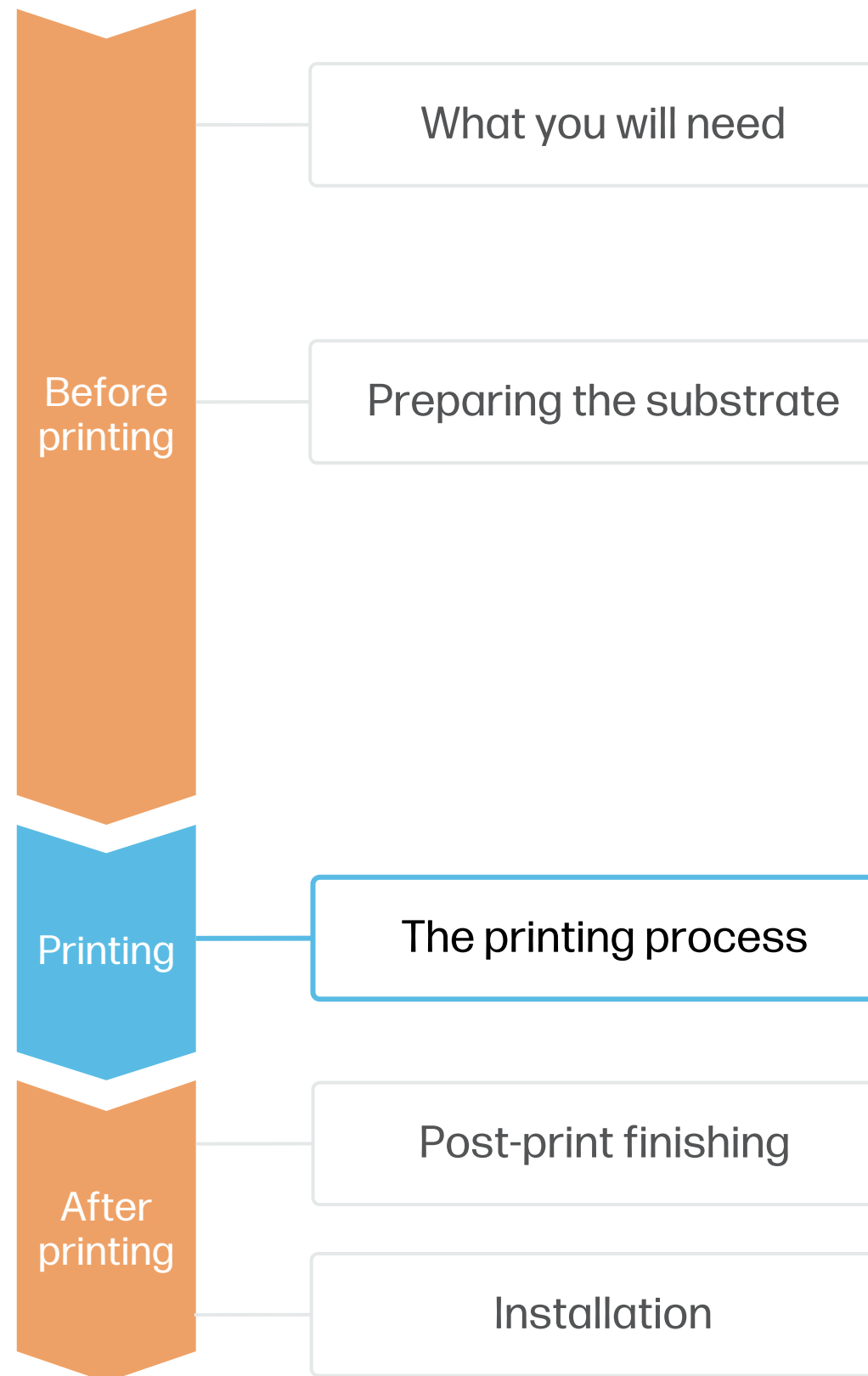

5. Loading the boards

4 | Load your printing files into HP SmartStream or other third-party compatible RIPs, like Onyx or Caldera.

5 | Select the **Sheet view** icon on SmartStream's toolbar, then choose the other parameters such as printing preset, thickness, size, print quality, or double-side settings.

6 | Click **Print**. If the job has multiple boards, wait for the Front Panel prompt to load the next board.

7 | If printing **double-side**, wait for the Front Panel prompt to flip the printed sheet(s) vertically, and load them again aligning them to the right.

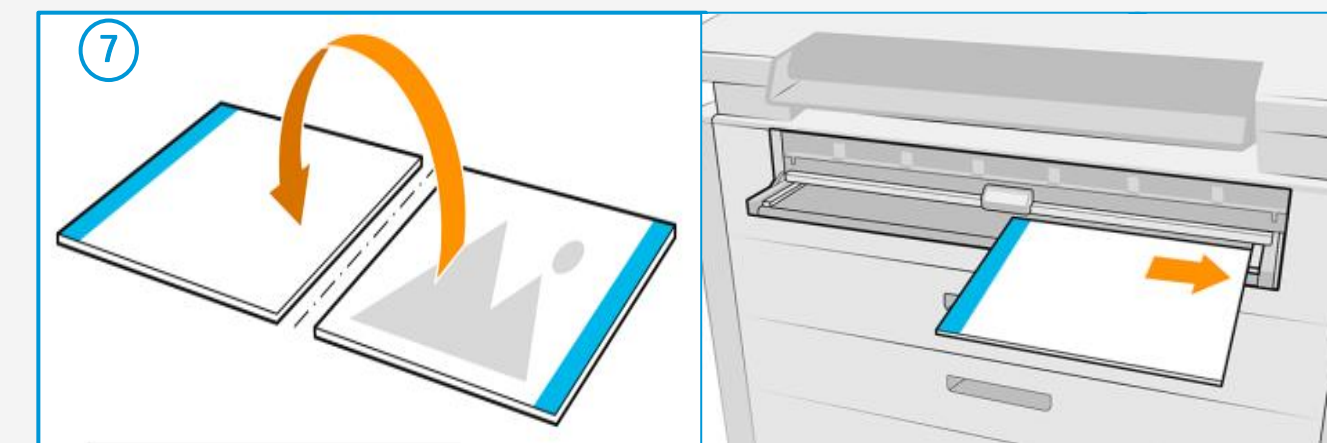
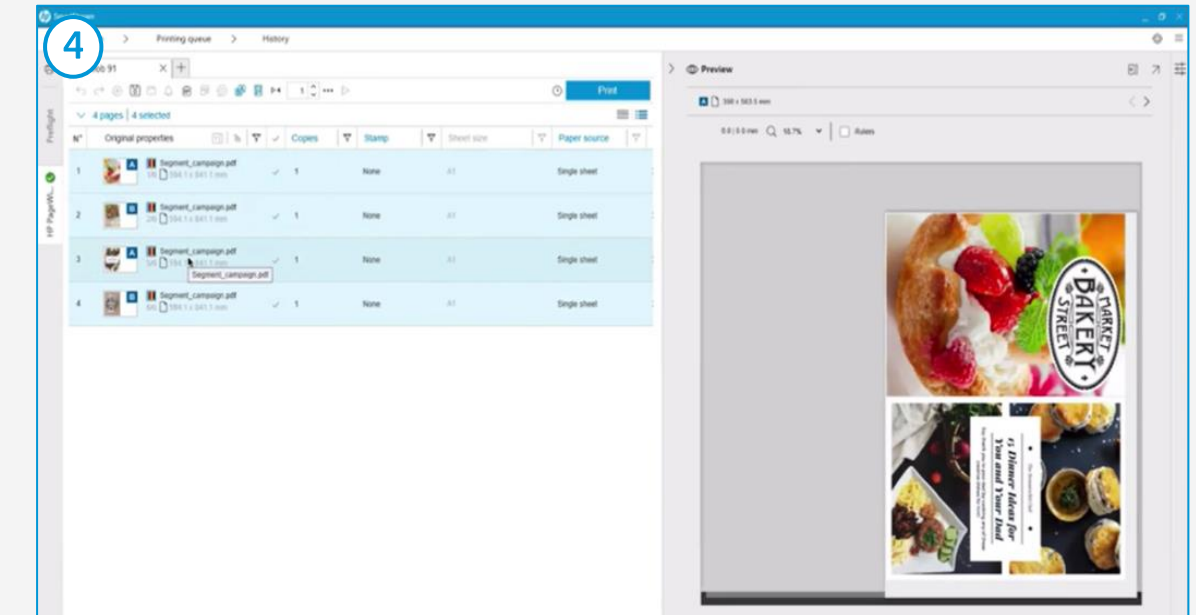

NOTE: Learn how to boost your workflow efficiency with HP SmartStream by enrolling on the training: "[Advanced certification - PWXLPRO5200and8200](#)" on HP Learn.

Post-print finishing

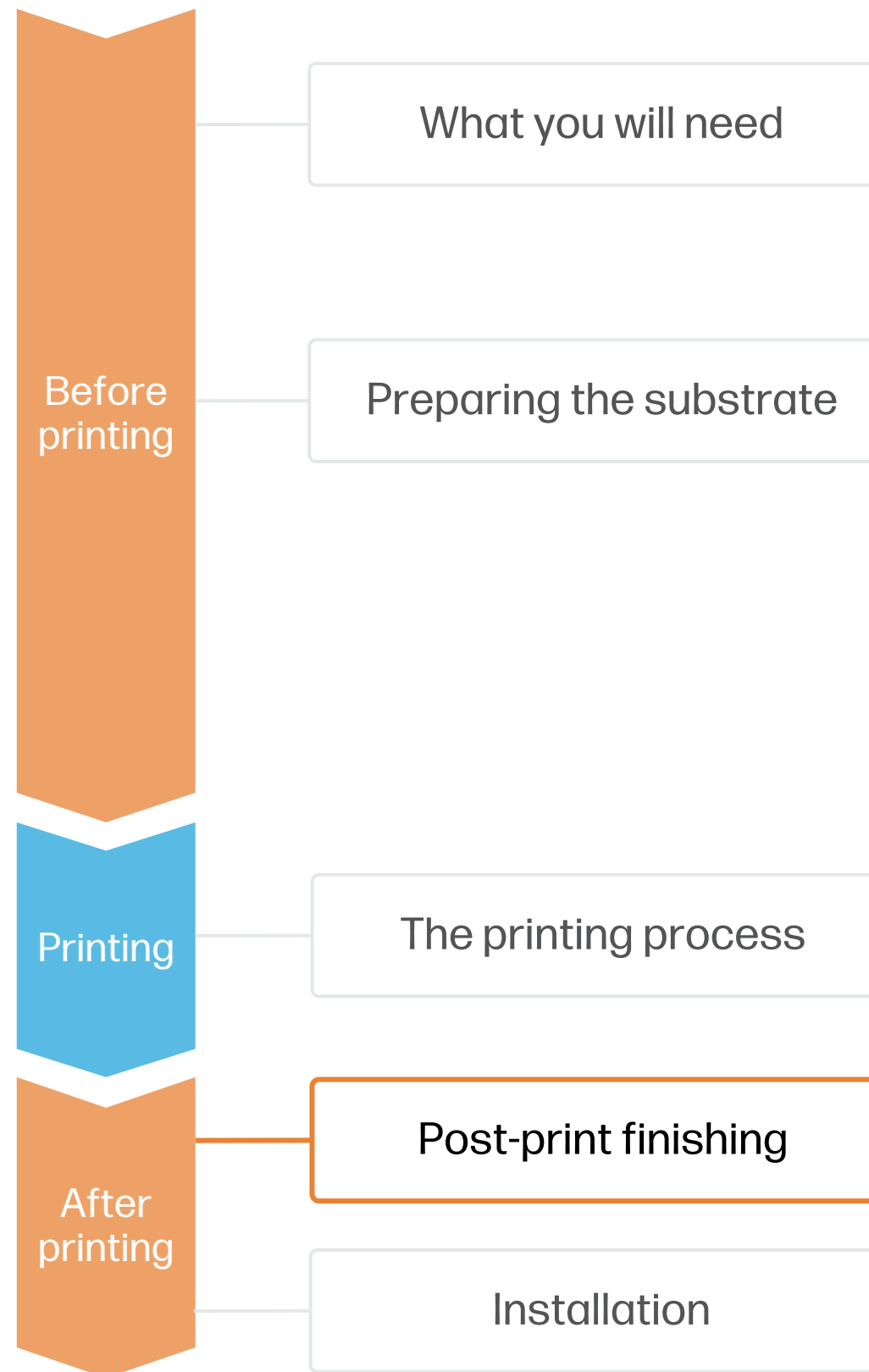

6. Cutting & bending (optional)

Printed HP Production Coroplus Board can be bent to create 3D signage, such as double-sided pole huggers, A-frame signs, or pole / bollard covers.

To fold the board, score the printed face using a sharp utility knife and safety edge, cutting only the face material without damaging the core, until it can be easily folded.

To create borderless signs, cut the white margins of printed boards using a sharp utility knife and safety edge ruler.



Double sided pole hugger



A-frame sign



Pole / bollard cover

Installation

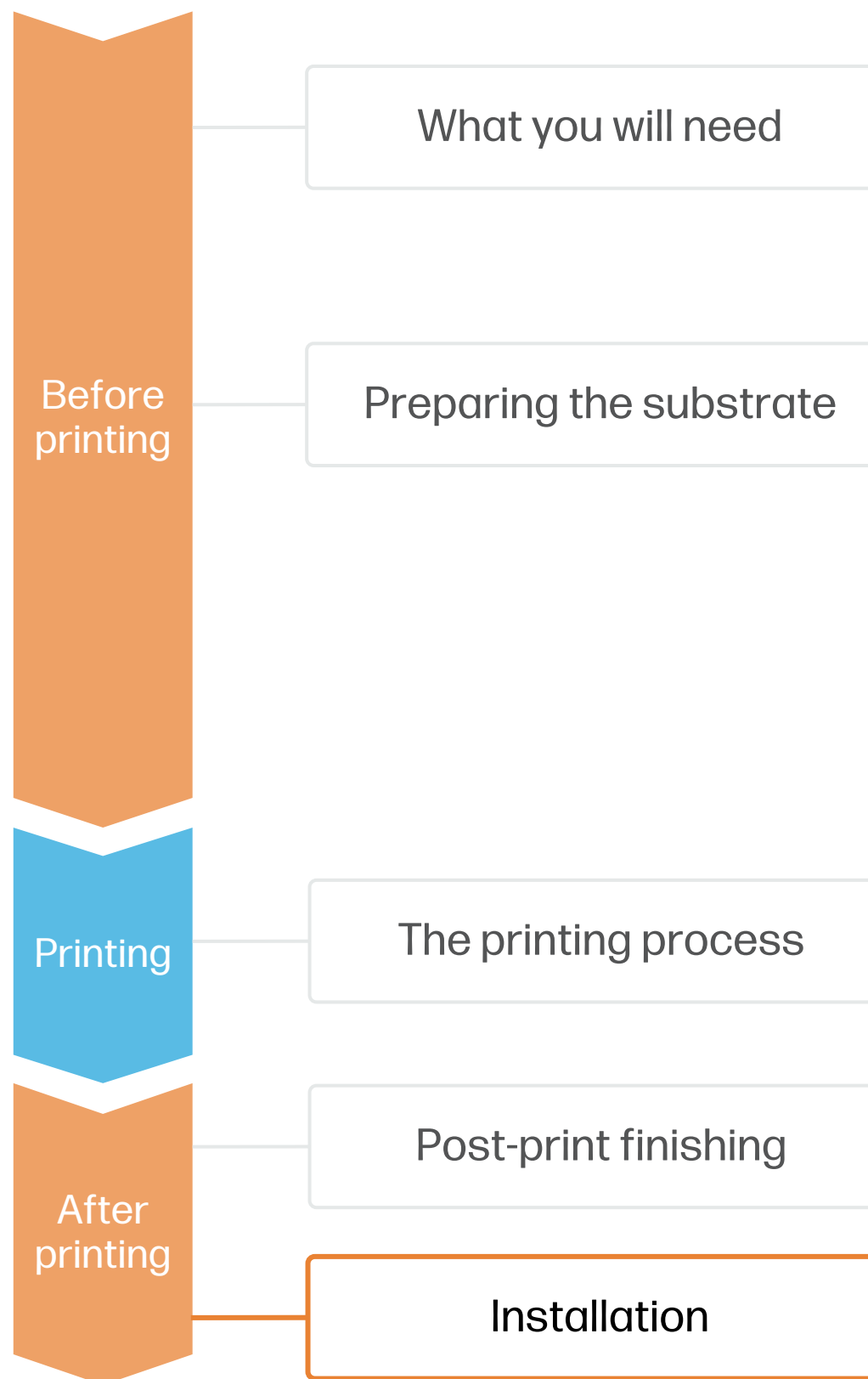

7. Installation

On a H frame stake: Insert one H-end into the ground firmly enough to withstand wind force. Insert the other H-end into the sign's flutes.

! IMPORTANT: Corrugated boards can only be installed on **H-stakes** with their **flutes oriented vertically** - which means boards can only be installed in landscape orientation. If portrait orientation is needed, install the boards on a wood stake.

VERTICAL FLUTES

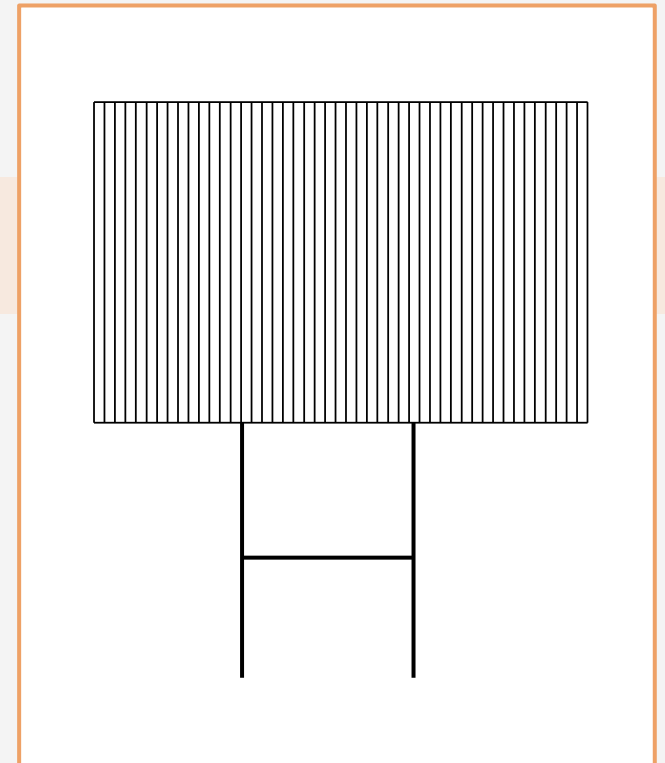

HORIZONTAL FLUTES

